











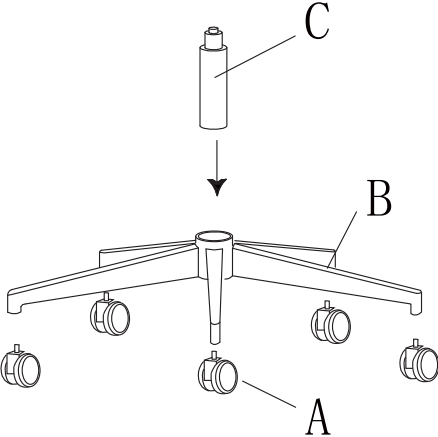
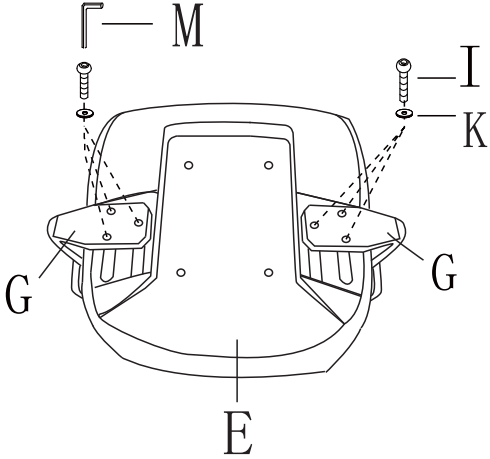
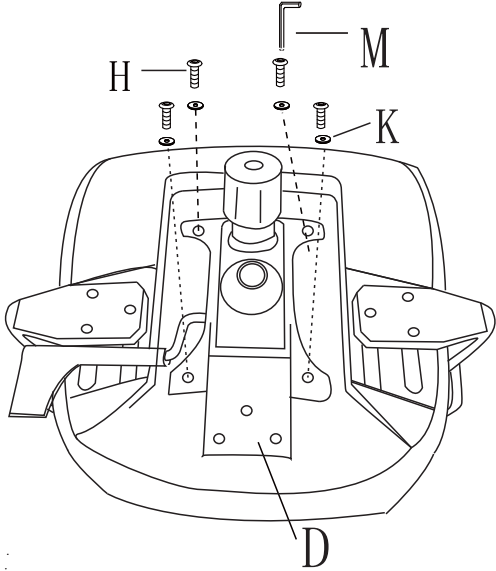

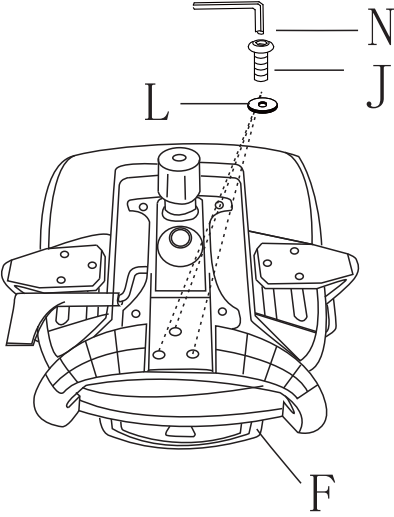
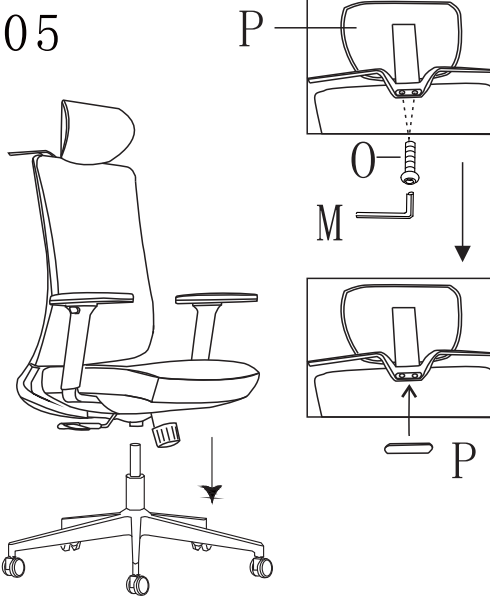



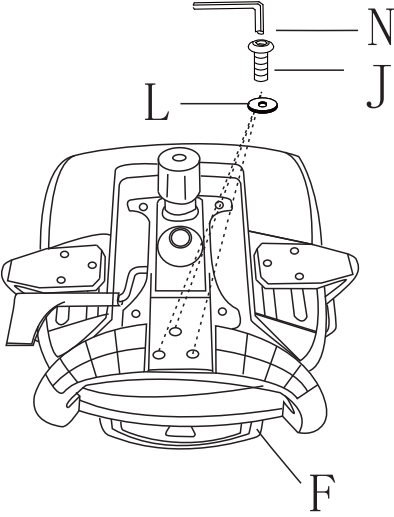
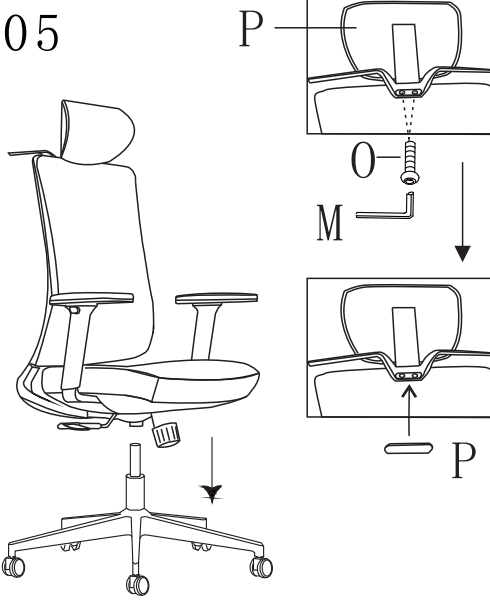

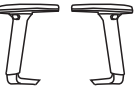

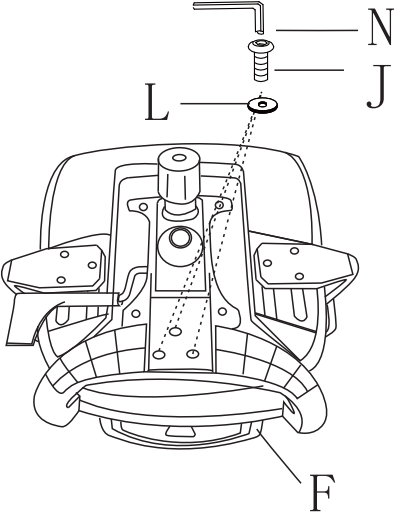
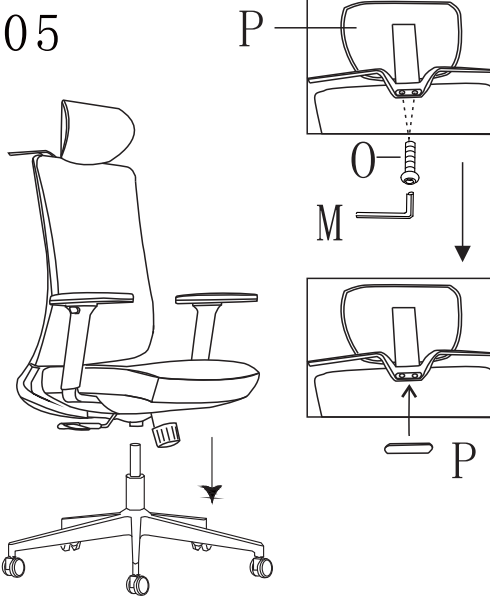



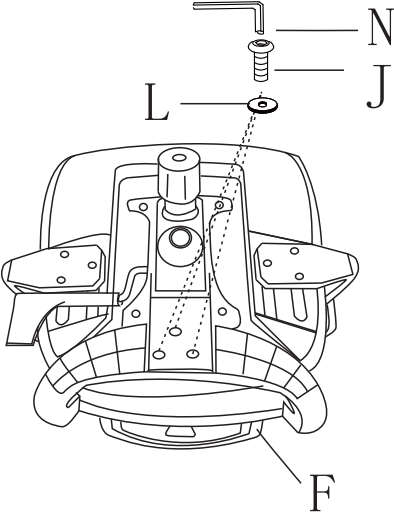
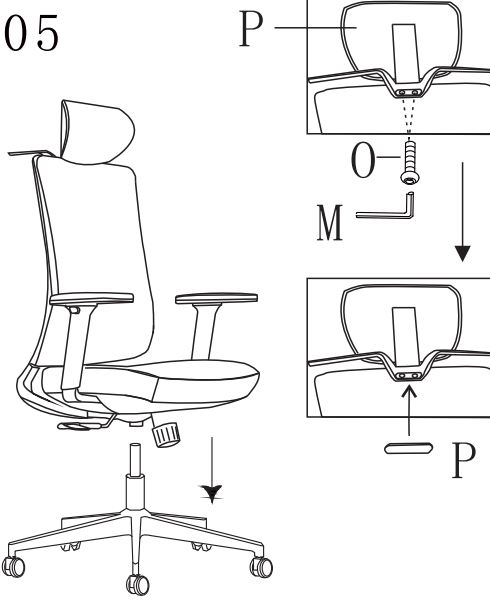

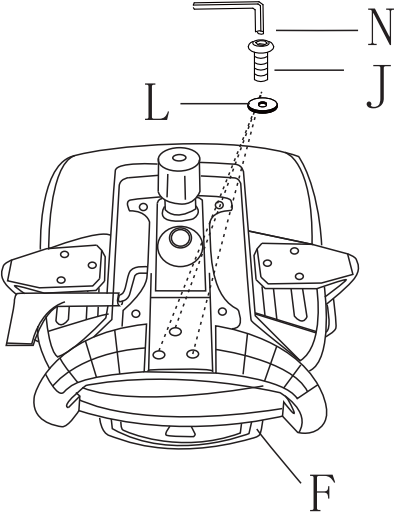
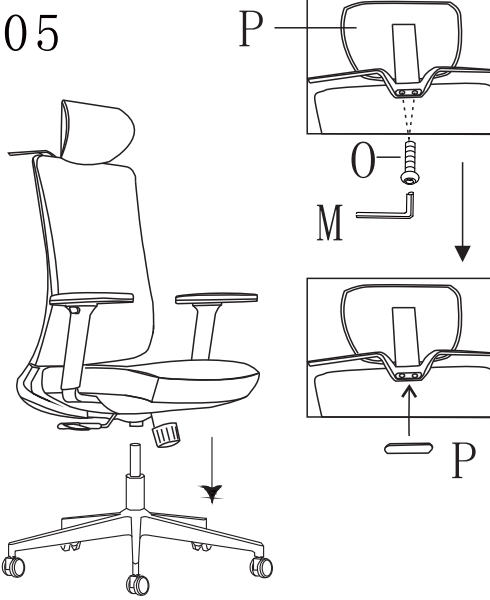

# Assembling

# Instruction

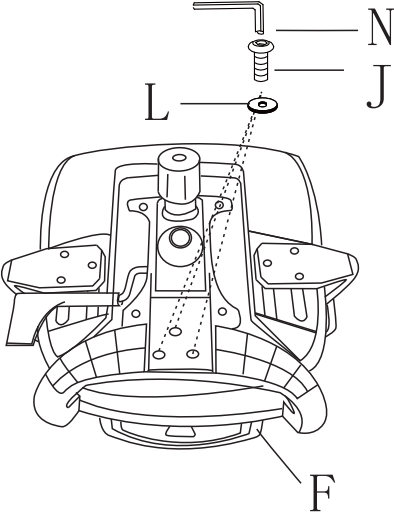
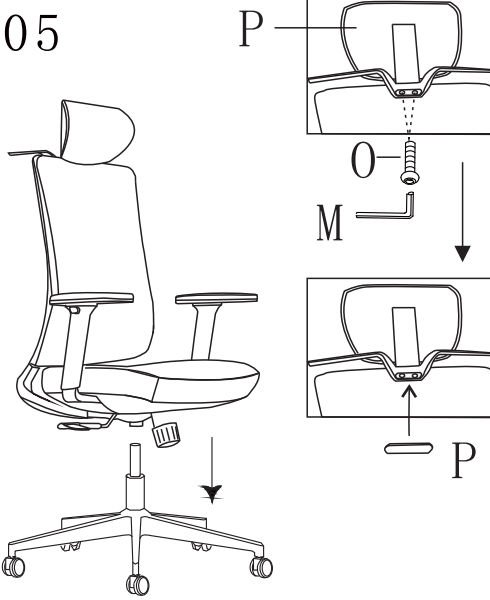
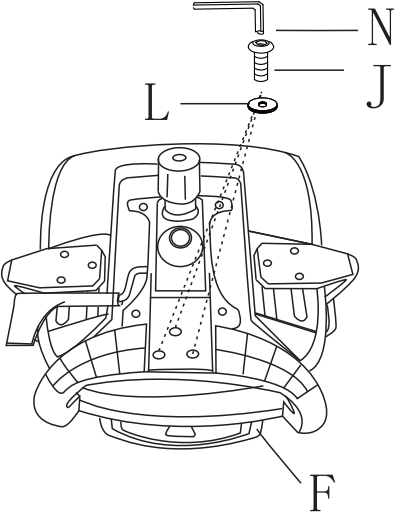
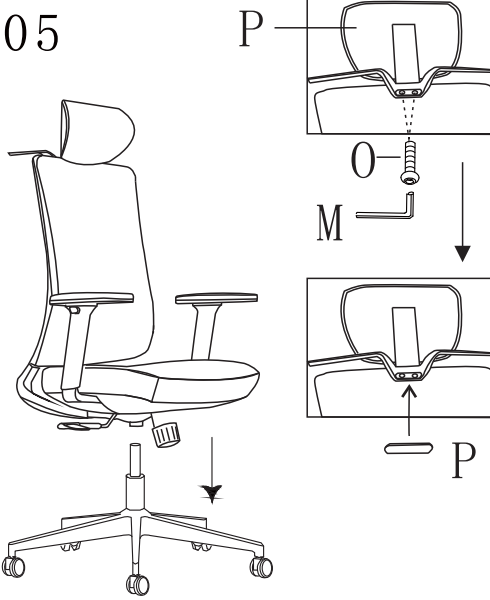
<p>A X 5</p> 	<p>B X 1</p> 	<p>01</p> 	<p>02</p> 	<p>03</p> 
<p>C X 1</p> 	<p>D X 1</p> 	<p>04</p> 	<p>05</p> 	<p>06</p> 
<p>E X 1</p> 	<p>F X 1</p> 	<p>05</p> 	<p>06</p> 	<p>06</p> 
<p>G X 2</p> 	<p>H X 4</p>  <p>(6x35) MM</p>	<p>06</p> 	<p>06</p> 	<p>06</p> 
<p>I X 6</p>  <p>(6x40) MM</p>	<p>J X 3</p>  <p>(8x40) MM</p>	<p>06</p> 	<p>06</p> 	<p>06</p> 
<p>K X 10</p> 	<p>L X 3</p> 	<p>06</p> 	<p>06</p> 	<p>06</p> 
<p>M X 1 (5) MM</p> 	<p>N X 1 (6) MM</p> 	<p>06</p> 	<p>06</p> 	<p>06</p> 
<p>O X 2</p>  <p>(6x27) MM</p>	<p>P X 1</p> 	<p>06</p> 	<p>06</p> 	<p>06</p> 